



Conversions by



Westinghouse-AO Smith Combo End Shield Conversion Installation Guide

PLEASE NOTE; Pinpotters having sweep reverse wire way wiring modification for aftermarket solid state start switches.

Wire way wiring must be returned to original pinpotter OEM specifications in order for machine to operate.

1-1

Using a 5/16 nut driver, remove four (4) through bolts and carefully lift stator from gear box assy.



Remove two screws securing receptacle housing to end bell to expose internal wiring.

Caution! Accurate recording of wire connection points is important.



Noting their original location, remove 4 wires connected to terminal board and brown wire for receptacle pin X to remove receptacle and housing from stator.



1-2

Remove two screws each from primary and aux switches.



Remove two screws from Klixon switch and remove end bell from stator.

Caution! Accurate recording of wire connection points is important.

Remove stator wires from terminal board then remove start switches from stator.

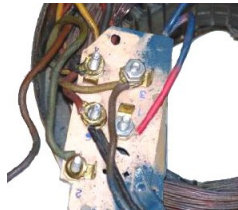

Inspect armature windings - check wiring for burns, broken wires or scored magneto. Inspect for dents or cracks.



Combo motor stator disassembly completed.



Inspect Klixon - Check for housing cracks and loose solder connections.



2-1

Caution! Accurate placements of wire connection points are important.

Reconnect stator wiring to proper terminal locations according to supplied wiring diagram.



Check again, for proper connections and wire placement before final re-assembly.



Secure Klixon to new motor end shield with supplied Mounting screws.

Re-install receptacle wires, to proper location, on new terminal board using supplied wiring diagram.

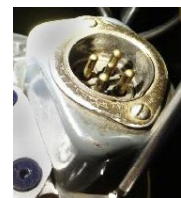
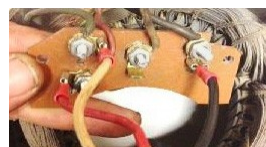

Secure receptacle and housing to new motor end shield then position onto stator.

2-2

Using a puller, remove bearing (6203) from rotor shaft.



Inspect rotor shaft - Check for burn marks, bent or broken cooling fan fins.

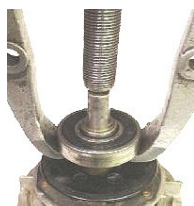

Replace unserviceable bearings.



Remove shaft spacer-collar, when present.



Remove centrifugal mechanism using two proportionately sized screw drivers forcing upwards until removed from shaft.



2-3

Install supplied *brake disc* onto shaft with bearing relief *collar* facing upward towards *bearing*.



Press *bearing* onto shaft against *brake disc*.



Install *stator* and new *end shield* onto rotor shaft and gearbox procedure not shown.

Insert and secure all (4) *end shield* mount screws.

2-4

Test-run *motor* (for proper startup) before inserting brake system *carbon brushes*, *spring* and *threaded plugs*, into their respective (4) openings.

Installation is complete.



For Technical Help -- CALL 308-627-4369

NOTE – Diagram below used for both 4 and 6 wire stator housings. The only difference is the brown wire connected to pin 1 of the Klixon thermal overload.

4 WIRE HOUSING – Brown wire on Klixon (pin 1) goes straight to X on the 5 pin receptacle.

6 WIRE HOUSING – Brown wire on Klixon (pin 1) goes to stator windings then to X on the 5 pin receptacle.

Brown wire always stays on X on receptacle.

STATOR WIRES

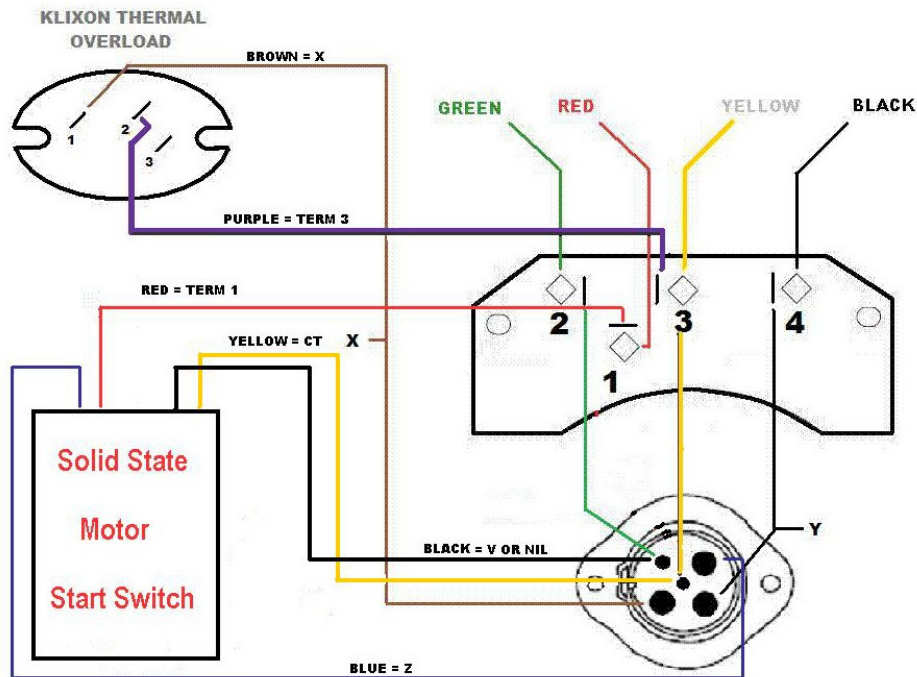

RECEPTACLE WIRES

**SOLID STATE MOTOR START SWITCH
INSTALLATION INSTRUCTIONS FOR WESTINGHOUSE COMBINATION MOTOR:**

Remove existing switches and centrifugal mechanism from stator and rotor.

Use the supplied terminal board in the kit and wire the connections according to diagram.

Start Switch Wires

Red wire: Terminal 1 →
 Black Wire: Terminal 2 →
 Yellow Wire: Terminal 3 →
 Blue Wire: (Z) Power Receptacle

Stator Motor Wires

Red Wire: Terminal 1
 Green Wire: Terminal 2 →
 Yellow Wire: Terminal 3 →
 Black Wire: Terminal 4 →

Power Receptacle Pins

Green Wire: (V) Nil
 Yellow Wire: CT
 Black Wire: (Y)

Brown Wire From Term #1 on Klixon goes to (X) on power receptacle
 Purple Wire From Term #2 on Klixon goes to Terminal Board #3

MAINTENANCE

During regular maintenance periods, check for worn carbon brushes and replace as needed. During brush replacement, clear carbon dusting from inside stator.

For Technical Help - - CALL 308-627-4369

TROUBLE SHOOTING - MOTOR DOES NOT START

Check all connections to and from switch.

Check for correct connections between Klixon thermal overload and receptacle to switch.

Check for bare or cracked wire shorted to stator housing.

PPP-70-ESB-WS - Contents

End shield & crank cover - Terminal board - Electronic start switch - Carbon brush brake system

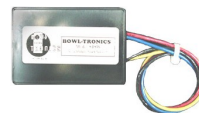

Klixon not included - shown mounted for reference.